

3735

3735 SERIES



3735A

BEACONS

LIGHTBARS/
MINIBARS

SAFETY
DIRECTOR™

LED DIRECTIONAL
LIGHTS

LIGHTING
SYSTEMS

BACK-UP
ALARMS

CAMERA
SYSTEMS

LED Light Head Surface Mount

This compact and versatile surface-mount LED directional light is ideal for applications requiring high intensity output, low-current draw and maintenance-free operation. These auxiliary LED heads feature a clear acrylic lens optic with LEDs that illuminate in the color of your choice. Warning capability can be customized by selecting from 11 different flash patterns (via a trigger wire).

Models

PART NO.	VOLTAGE	AMPS	MOUNT
3735X	12	0.3	Surface

Replace X in part number with desired color: A=amber, B=blue, C=clear, G=green, R=red

Features and Benefits

- ABS plastic housing with encapsulated electronics
- 11 flash patterns
- Discrete units are colorless when not illuminated
- LEDs offer a long, maintenance-free service life
- CE, e
- Temperature Range: -22°F to +122°F (-30°C to +50°C)
- Warranty: 1 year

Accessories

UNIVERSAL
A3730BKT



TRUNK
A3730TNK



DECK
A3730DCK



WINDOW
A3730WIN



LICENSE
A3730LIC

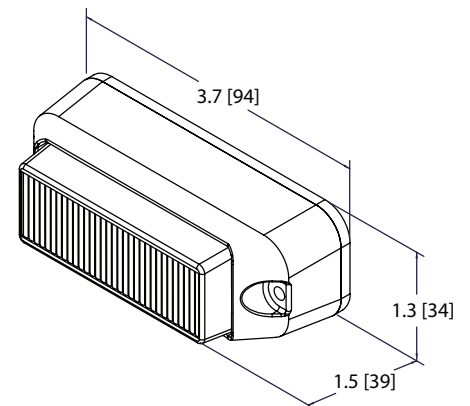

Flash Patterns (11)

Steady Burn	Quad
Slow Single	Quint Hold
Fast Single	Pulse8
Double	Constant Pulse8
Fast Double	Cycle Flash
Triple	

ECCO®

833 West Diamond Street
Boise, Idaho 83705

T: 800-635-5900 or 208-395-8000
F: 800-688-3226 or 208-395-8190
www.eccolink.com

A DIVISION OF
ECCO
GROUP®