

Spencer® Vacuum Cleaning Systems

Serial No:

Model No:

Filter Bags:

Handling, Installing and Operating Instructions

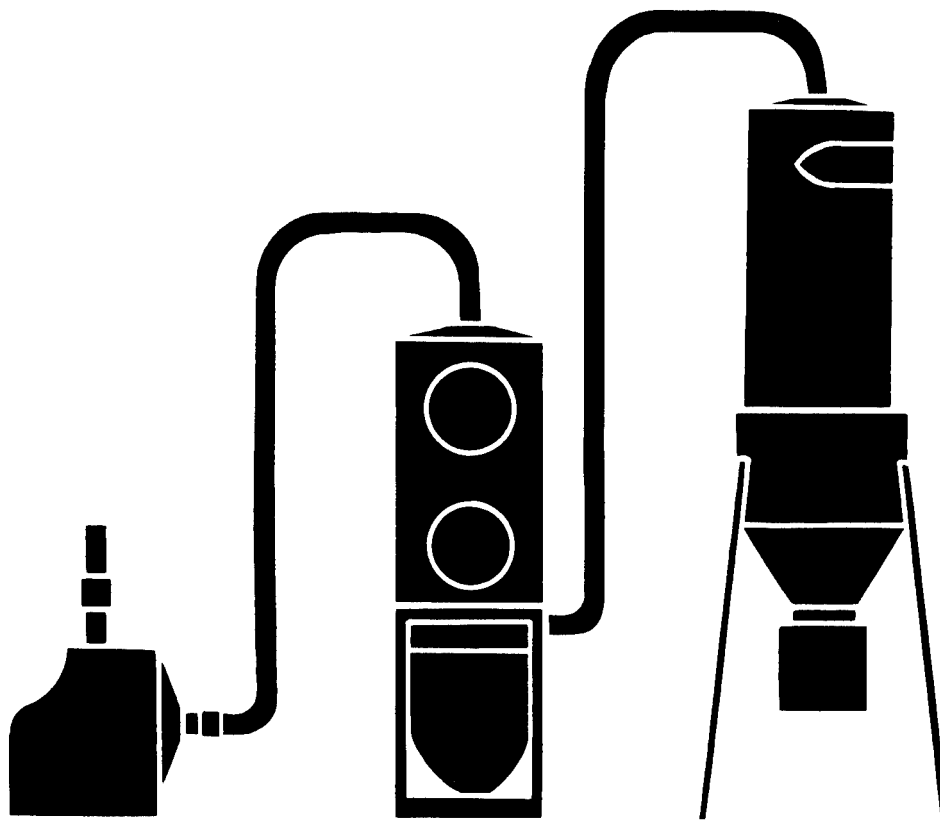

Important

Do not operate machine in unstable, low-flow range (surge).

Read and become familiar with this manual prior to uncrating and installing your Spencer Vacuum equipment. This precision equipment is capable of extended service and lifespan. Realization of this potential can best be achieved through proper handling and adherence to the instructions detailed here. Damage resulting from failure to follow correct procedures will void warranty.

Contents

	Page
I General Instructions	2
II Coupling Alignment	4
III How to Order Replacement Parts	5
IV Lubrication Instructions	6
V Standard Overhung	8
VI Four Bearing Overhung	10
VII Four Bearing Outboard	12
VIII Centrifugal Separator	14
IX Tubular Bag Separator	14
X Filter Bag Information	15
XI Wet Separator	16
XII Portable Wet Separator	16
XIII Trouble Shooting Guide - Separators	17
XIV Trouble Shooting Guide	18-19

I. General Instructions

Illustrations contained here apply to three types of Spencer Fabricated Vacuum Producers. Use the illustrations or consult factory to determine which machine you have, then read instructions paying particular attention to those which are unique to your machine. When in doubt, consult Spencer. For Power Mizer® Cast Centrifugal Vacuum Producers refer to Form WW for handling, installing and operating instructions.

Important

Read and become familiar with this manual prior to uncrating and installing or storing machinery—it is a precision piece of equipment capable of extended service and lifespan. Realization of this potential can best be achieved through proper handling and adherence to the following instructions. Damage resulting from failure to follow correct procedures will void warranty.

Spencer Service

Spencer service begins upon receipt of your request for equipment purchase. Our engineers welcome the opportunity to discuss your problems and will assist in determining specification requirements if so desired. To serve you promptly, we maintain a large inventory of electric motors and machine parts. Also, by combining under one roof the constantly supervised manufacturing, assembly, and test procedures, Spencer can assure you of a unit capable of optimum performance under the most severe service conditions. All Spencer machines are factory tested for load capacities and vibrational characteristics. This assures long, trouble-free operations.

Warranty

We warrant that this product will be free from defects in material and workmanship for a period of 18 months from date of shipment or 12 months from date of startup, whichever comes first. Within the warranty period, we shall repair or replace, F.O.B. our Factory or designated service center, such products that are determined by us to be defective.

This warranty will not apply to any product which has been subjected to misuse, negligence, or accident or, misapplied or improperly installed. This warranty will not apply to any product which has been disassembled, repaired or otherwise altered by any persons not authorized by our Service Department.

The guarantee of the motor, control, and component manufacturers govern the extent of our guarantee on such equipment.

2 Note: For complete warranty information, including our limitation of liability, consult Spencer's Terms and Conditions of Sale - Form 706.

Warranty work on motors, controls, and components must be authorized by Spencer and must be performed in an authorized shop as designated by the motor, control, and component manufacturers. The Spencer Turbine Company reserves the right to invoice all expenses incurred when repairs are made in the field at the specific request of the customer.

Handling

Caution: Do not lift by the shaft end or bearing housing; use lift rings or slots in base.

This machine has been carefully balanced and tested at our factory. It is essential that it be handled with care during installation in order that you may be assured satisfactory performance.

Storage

Caution: If machine is to be stored for an extended period of time, it must be carefully protected from dampness and dirt and the shaft should be rotated a few times by hand, every week.

On Four Bearing Overhung and/or Four Bearing Outboard type machines, bearings must be replaced at customer expense if start up occurs one year beyond date of shipment.

Failure to comply with any of the preceding will void warranty.

Location

Caution: Do not locate unit or controls in excessively hot area (> 104°F) unless the equipment has been specifically designed for this condition.

Before placing the machine in its operating position, be sure that the vacuum system components are readily accessible for servicing **by allowing several feet of clear space around the machine. Inaccessibility can prove costly in both time and labor.**

Foundation

Caution: Vacuum Producers should not be bolted down.

No special foundation is necessary for Spencer Vacuum Producers. A level concrete floor or block is recommended, although any other substantial non-resonant floor will prove satisfactory. The Vacuum Producer's base should be placed on the furnished cork isolating pads or equivalent. Level machine by inserting shims between cork pads and machine frame, if necessary.

Tubing

Tubing should be properly aligned and supported so as not to produce any stress or strain on the machine casing. It is necessary that a flexible connector be used to connect the machine to the tubing system. It is necessary that tubing be restrained to prevent its movement away from the Vacuum Producer due to air pressure when it is operated.

Inlet and Outlet Sleeves

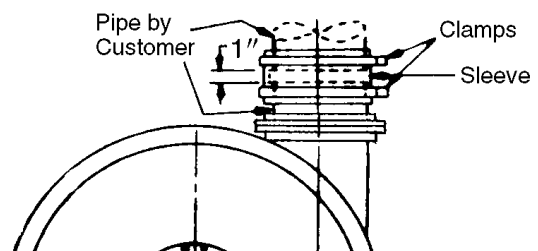

All tubing should be of ample size to minimize frictional loss. It is absolutely essential that all joints be airtight and that there be no leaks in the system. Leaky air pipes consume a surprising amount of power and impair the operating efficiency of the system.

A rubber connecting sleeve is supplied with most machines. It should be installed so that it covers a gap of approximately one inch as illustrated. The mounting clamps should be tightened to effect an airtight connection.

It is important that the tubing or piping not touch or butt the Vacuum Producer; there must be a gap between the machine and piping or tubing.

Electrical

Caution: Be sure motor, starter, controls and other electrical equipment is the proper type suitable for the application and environment and complies with all applicable codes.

Be sure that the motor furnished with this machine is rated for the same type of voltage available at the installation site. In making the electrical connections, follow the wiring instructions furnished. Wire and fuses should be of ample capacity to insure that proper voltage is maintained at the motor terminals while starting and running. It is important that proper starting equipment be used. All AC machines should be equipped with a magnetic contactor or a manual or automatic compensator depending on the machine size and the installation regulations of the local power company. The starters should have thermal overload protection as well as true low-voltage protection.

Start-Up

Coupling-Equipped Machines

Caution: Before start-up, the coupling must be aligned in accordance with the information contained in Section II, Coupling Alignment, or with the manufacturer's instructions accompanying each coupling.

The following procedures apply to start-up of all Spencer Vacuum Producers.

Caution: The Vacuum Producer must be electrically wired with regard to the correct direction of rotation. A direction-of-rotation arrow is affixed to the casing. To check rotation direction depress start button, immediately depress stop button and observe that the motor drive shaft rotation coincides with the arrow attached to the casing. Available discharge positions (viewed from intake end) and the correct relationship of the discharge position to rotation are shown in the following diagram.

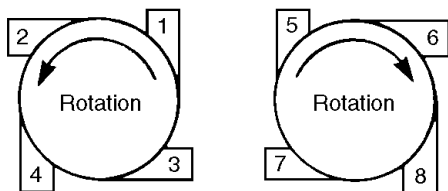

Under no circumstances should the Vacuum Producer be operated without being connected to the tube system with which it is used or motor overload will occur.

When starting up a Vacuum Producer it is recommended that a blast gate or other control device be closed. When first starting the Vacuum Producer, an ammeter should be connected to the motor circuit and the control device opened

until full load current is reached. At this point, the blast gate locking nut should be tightened. This prevents motor overload. The blast gate may then be used for throttling purposes. Current readings at motor must be compared with readings on ammeters (when furnished) to be sure they are the same. If readings are not the same, contact Spencer's Service Department.

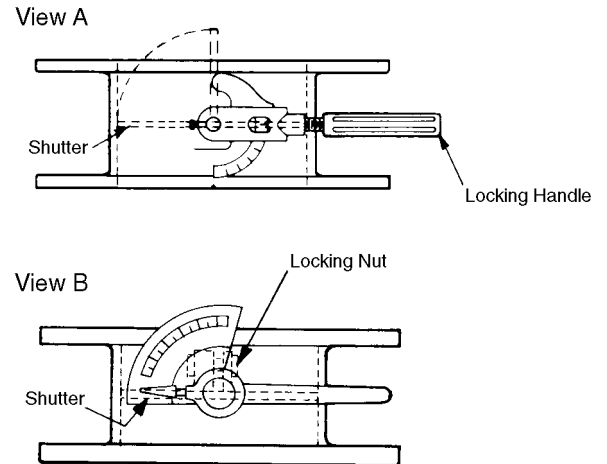

Periodic Operation

Caution: All Vacuum Producers should be operated periodically. This can be accomplished through bi-weekly alternate operation of the machine(s).

Parallel Operation

Caution: Check valves must be installed on the inlet of each Vacuum Producer connected in parallel to prevent air flow back through the unit not in operation. When operating two or more Vacuum Producers in parallel it is necessary to be sure that each machine carries its respective share of the load.

After accomplishing start-up of each machine, proceed as follows. Check the current reading at each motor to be sure they are the same. If current readings are approximately the same it indicates Vacuum Producers are sharing equal system load. It may be necessary to re-adjust the control device to attain similar readings on the ammeters.

In most cases low flow protection for the equipment is required.

Caution: Operation of Positive Displacement Vacuum Producers in parallel with Centrifugal Vacuum Producers is not recommended and may result in damage to the Centrifugal Vacuum Producer.

Surge (Unstable Low Flow)

Caution: Do not operate the Vacuum Producer below the minimum safe operating flow. Operation below the minimum flow will result in surge or in excessive discharge temperatures. Damage to the Vacuum Producer because of operating below minimum safe flow will not be covered by Spencer warranty.

A unit in surge can produce a breathing or pulsating discharge noise. It may also be detected by movement on an ammeter scale or manometer. Increasing the volume flow sufficiently should eliminate this condition. This may be accomplished by bleeding air into the Vacuum Producer.

II. Coupling Alignment

For Power Miser® Cast Centrifugal Vacuum Producers refer to Form WW.

Caution: The coupling on this machine was carefully aligned at the factory and the coupling halves and shell(s) marked to indicate optimum relative position. However, transportation may have caused coupling misalignment. It is essential, therefore, that the motor and Vacuum Producer shafts be checked for misalignment and carefully realigned if necessary after installation and before start-up, as misalignment can cause destructive vibration.

Coupling alignment should be rechecked again after an hour's operation. Final alignment should be made at average operating temperature. After each alignment check, add lubricant per instructions and replace coupling guard.

On certain Vacuum Producers, the coupling is disassembled after factory alignment and marking. The coupling halves are specially protected against the elements and the machine is shipped. Prior to start-up, it is necessary on these machines to assemble, align key ways using factory markings, and lubricate in accordance with the instructions supplied with the machine and contained here.

Coupling alignment provides for aligning, in the horizontal and vertical planes, the motor shaft with the blower shaft, and insuring adequate clearance (gap) between the two coupling halves. Only qualified maintenance personnel should attempt to align a coupling. If doubt exists as to competency or if problems arise contact The Spencer Turbine Company.

Sier Bath Coupling (See accompanying illustrations)

Sier Bath gear type couplings are the most common coupling supplied with Spencer equipment. These are manufactured to our rigid specifications.

Sier Bath Coupling Size	Dimension "C" (hub to hub) Gap
7/8	1/8
1 1/2	1/8
2	1/8
2 1/2	1/4
3	1/4
3 1/2	1/4
4	1/4
4 1/2	1/4
5	1/4
6	1/4
7	3/8
9	1/2
11	1/2
12	1/2

Remove one snap ring and slide the sleeve off the hub halves. Using a feeler gauge, verify that the gap between coupling halves, is in accordance with the chart above.

Caution: Be careful because some motor shafts are spring loaded axially. When using a feeler gauge take care not to compress the shaft and disturb the normal at-rest position.

To align this coupling, Spencer recommends one of the following procedures.

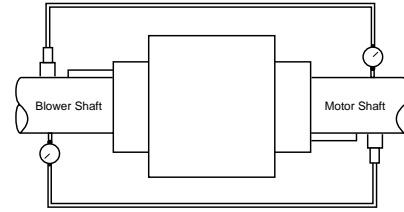

Reverse Indicator Method (Preferred)

1. Reinstall the coupling sleeve, seal and snap ring.
2. Clamp dial indicators on shafts, 180 degrees apart.
3. Place indicator probes on opposite shafts as shown.
4. Rotate both shafts simultaneously in the correct operating direction, taking readings at 90 degree intervals.
5. Adjust motor to achieve parallel and angular alignments. If questions arise, contact the Spencer Service Dept.

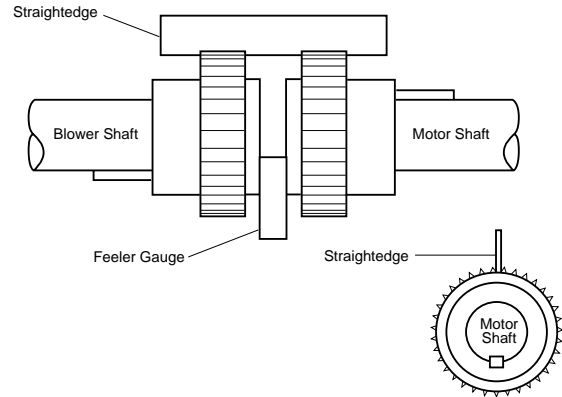

Straight Edge Method (Permissible)

1. Remove the old lubricant and clean the hub teeth.
2. Set a machine shop quality straight edge across the coupling hubs (at the root diameter of the gear teeth).
3. Adjust the motor so the straight edge is evenly supported between the coupling hubs at the 3, 6, 9, and 12 o'clock positions.
4. Using a feeler gauge, measure the clearance between the coupling hubs at the 3, 6, 9, and 12 o'clock positions.
5. Adjust the motor so that the gap is identical at the 3, 6, 9, and 12 o'clock positions and in accordance with the dimension "C".

Caution: Be sure to relubricate coupling after alignment and before operation.

Coupling Alignment with Sleeve Bearing Motors

Caution: Where sleeve bearing motors are used, it is necessary to complete the following procedures before coupling alignment is attempted.

Unless otherwise specified by the customer, a flange type gear coupling should be used for both 1800 and 3600 RPM applications. Do not use a sleeve type coupling.

Sleeve bearing motors have a specified end play. End play limits and the magnetic center (where motor will run) should be scribed on the shaft by the manufacturer.

When aligning a sleeve bearing motor with a machine, use the following procedure:

1. The motor shaft must be level.
2. Position the motor so that when the rotor is pushed toward the machine as far as it will go, there will be 0.030 clearance between the ends of the machine and motor shafts (or the alignment faces on the coupling hubs).
3. Proceed with the coupling alignment in accordance with applicable instructions.

III. Replacement Parts

How to order replacement parts

When ordering replacement parts, it is important that the information you furnish to Spencer is correct and complete. Be sure when reading nameplates that you obtain the correct information. Record nameplate information on one of the typical nameplates shown here and on the cover to use as a reference when ordering parts. Remember, the more complete the information, the quicker the order will be processed; incomplete information will result in unnecessary delays and expense through callbacks. When in doubt, consult the factory for further information.

To order replacement parts, furnish the following:

1. Record machine serial number and catalog/model number from machine nameplate.
2. Record motor horsepower from motor nameplate.
3. Measure and record the casing diameter.
4. Refer to applicable illustration in the instruction manual and locate needed item by its circled call-out number. Refer to call-out list for nomenclature and record.
5. When ordering impellers and deflectors be sure to include the letter designation shown on the applicable illustration. An alternate method would be to count the number of impellers from the end of the casing.
6. Include the form number from which you have extracted the nomenclature. The form number is shown in the bottom right corner of the cover page and will read AA, EE, etc.

Typical Nameplate

Spencer® Vacuum Producer

Read instruction manual before starting equipment.

Serial No. Model No.

Manufactured under some or all of the following -
Registered Trademark: 62,801; 140,976; 652,701;
1,616,417; 134,026; 341,418; 1,348,270; 959,254;

The Spencer Turbine Company, Windsor, CT 06095
860-688-8361

Made in U.S.A. Plate No. PLN-90050

The following are recommended spare parts:

Tubular bag separator.

Complete set of replacement bags.

Standard Overhung (refer to drawing on page 9 for item numbers).

Item Number	Nomenclature
2	Division head packing
4	Rope packing
9	Interstage packing
12	End head gasket
15	Drive End motor bearing
19	Opposite Drive End motor bearing

Four Bearing Overhung (refer to drawing on page 11 for item numbers).

Item Number	Nomenclature
1	Flexible coupling
5	Coupling End bearing
5A	Blower End bearing
6	Division head packing
14	Interstage deflector packing
16	End head gasket
18	Rope packing
21	Drive End motor bearing
23	Opposite Drive End motor bearing

Four Bearing Outboard (refer to drawing on page 13 for item numbers).

Item Number	Nomenclature
2	Drive End motor bearing
3	Flexible coupling
10	Rope packing
18A	Outboard bearing(s)
20	End head packing
22	End head gasket
25	Interstage deflector packing
32	Division head packing
34	Inboard bearing
37	Opposite Drive End motor bearing
38 or 39	Metallic packing (if machine equipped with packing box).

IV. Lubrication Instructions

For Power Mizer® Cast Centrifugal Vacuum Producers refer to Form WW.

Caution: Recommended bearing grease is Chevron SRI, Number 2. Use of any other grease will void warranty.

General

Proper lubrication procedure is important to Vacuum Producer maintenance. These instructions should be closely followed to assure trouble-free operation of the equipment.

Standard Overhung Lubrication

Spencer's Standard Overhung Vacuum Producers do not require lubrication except for motor bearing lubrication required by the motor manufacturer. See paragraph entitled **Motor Bearing Lubrication**.

Four Bearing Overhung and Four Bearing Outboard Bearing Lubrication

Spencer Four Bearing Overhung and Outboard Vacuum Producers are equipped with deep-groove radial ball bearings designed to carry the thrust and radial loads. These bearings are packed with the proper amount and grade of lubricant before the unit is shipped from the factory. For this reason, **lubrication prior to first operation is not recommended and should not be attempted.**

Bearing Lubrication Procedure and Frequency Guide

Lubrication is required based on operating frequency and conditions. **Many bearing failures are caused by excess grease which results in over-heating and consequent bearing failure.**

The Vacuum Producer bearings, as lubricated at the factory, carry an adequate amount of proper grade of grease for 1500 to 8000 hours of continuous operation prior to lubrication, depending upon atmospheric conditions and size. An average lubrication interval therefore should be established based on existing conditions. Several factors contribute to frequency of lubrication:

1. Operating temperatures (bearing)
2. Indoor or outdoor operation
3. Dusty or clean atmosphere
4. Ambient temperature
5. Predicted duty cycle
6. Bearing size and speed

Assuming an ideal 8000 hour lubrication interval, reduce the time factor by applying the preceding conditions as follows:

Operating Condition	*Lubrication Interval Blower Bearings
I. 1. 120°F to 170°F bearing temperature 2. Indoor installation 3. Clean atmosphere 4. 40°F to 100°F ambient temperature 5. Continuous operation	4000-6000 average operating hours
II. Same conditions as "I", above except: Intermittent operation	6000-8000 average operating hours
III. 1. 120°F to 170°F bearing temperature 2. Outdoor installation 3. All atmosphere conditions 4. 0°F to +120°F ambient temperature 5. Continuous operation	3000-5000 average operating hours
IV. Same conditions as "III", above except: Intermittent operation	5000-7000 average operating hours

***Note:** Higher limits apply to smaller bearings (#308 and smaller). Lower limits apply to large bearings.

An extremely dirty atmosphere, in addition to the above factors, could decrease the lubrication period as much as 50%.The above chart serves only as a guide.

To lubricate blower bearings, proceed as follows:

1. Shut down machine.
2. Remove guards as necessary.
3. Inject the recommended grease (Chevron SRI No. 2) using a grease gun. The amount of grease will vary with bearing size.
4. Reinstall guards and restart the machine.

Caution: Do not run Vacuum Producer unless guards are properly installed.

Recommended Bearing Lubricant Type

The bearings of Four Bearing Outboard and Four Bearing Overhung Turbo Vacuum Producers are packed at the factory with Chevron SRI, Number 2 grease. The general specifications are:

Grade or consistency	.#2
Thickener	.polyurea
ASTM Dropping Point	.480°F
Work Penetration	.270
Base Oil Viscosity	.600 SUS @ 100°F
Color	.Blue-Green

Chevron SRI, Number 2 is available from Spencer.

Note: The intermixing of incompatible greases will result in loss of lubrication and bearing failure which is NOT covered under the Spencer warranty.

Lubrication of Replacement Bearings (Four bearing designs only) When installing new bearings, it is necessary to repack bearings with grease. Do this by forcing grease into the bearings and “butter” both sides with grease so that the grease is flush with the race. Use only Chevron SRI #2 grease. For outboard tandem bearing installation, follow procedures packed with each new bearing set. Remember, these bearings are manufactured as a set to Spencer’s rigid specifications.

Motor Bearing Lubrication (Applicable to all)

Follow motor manufacturer’s recommendations. Some motors equipped with sealed bearings are not intended to be re-lubricated. There are, therefore, no grease or drain plugs on motors of this type.

Flexible Coupling Lubrication

Gear type couplings must contain lubricant at all times. Re-lubricate after checking alignment. Follow the coupling manufacturer’s recommendations.

Lubricated couplings on machines shipped from Spencer have been serviced with Texaco Coupling Grease (#1912). All couplings should be re-lubricated prior to start-up.

To re-lubricate Sier Bath without disassembling coupling, remove both lube plugs and position lube holes at 45° to horizontal. Force grease into top hole until clean grease flows out of opposite lower holes. Reinstall both plugs and wipe off all excess grease. Re-lubricate every six (6) months.

Coupling Half Removal

Gear type couplings generally require the application of heat and the use of a puller to remove.

V. Standard Overhung Machine

Instructions for Disassembly and Reassembly (Multi-Stage)

Warning: Be sure all electrical power is disconnected prior to performing Vacuum Producer maintenance.

Caution: Parts must be reassembled in exactly the same relative positions. Therefore, it is recommended that each part be marked as it is removed from the machine to facilitate later reassembly. It is especially important that the location of each impeller, as well as its position on the shaft, be marked.

When ordering replacement impellers and deflectors, refer to the Notes on accompanying illustration.

General Configuration

The most common Spencer machines (standard overhung type construction) have the impellers mounted directly on the extended motor shaft and are available as either single-stage or multi-stage units. The multi-stage units are provided with deflectors to channel the air efficiently from one impeller to the next. The single-stage units are equipped with one impeller mounted between the end head and division head of the machine housing. The motor bearings support the shaft and impeller assembly. Besides the customary motor maintenance, no additional attention is required by the unit.

Disassembly

1. Remove End Head Bolts (5) and End Head (6).
2. Mark the motor shaft and impeller (8) hub with an arbitrary 12 o'clock reference point. Remove the first stage impeller (8A) and mark it for reference during reassembly.
3. Check axial position of each deflector (7) at four radial points with reference to end of casing and record for reference when reassembling unit.
4. Remove spacer (14A) holding rope packing (4) in place. Mark spacer for reference during reassembly.
5. Remove rope packing (4) holding deflector in place. Remove deflector (7A). Mark for reference during reassembly.
6. Proceed to remove remaining stages in the same way, marking each component to insure proper reassembly. Note: Division Head (3) cannot be removed.
7. Unbolt division head packing plate (2A) and slide packing plate and packing (2) back on the shaft.
8. Remove motor mounting bolts and slide motor (1) back.

Reassembly

1. Place the division head packing plate (2A) and packing (2) on the shaft. If for any reason the packing (2) is damaged, replace it. Install the motor (1) in the casing in its original position. Be sure that the shaft is centered in the casing. Assemble the packing (2) and packing plate (2A) to the division head.
2. Run the motor (1) to check for vibration. If excessive vibration is present, check the shaft for runout.
3. Place the first impeller (8C) on the shaft up against the division head (3). Mark the shaft approximately 1/8" out and withdraw the impeller to this point. This will insure a clearance of 1/8" behind the impeller. Tighten the hub securely.
4. Inspect the interstage packing (9), if applicable, on deflector (7B) and replace if damaged.
5. Place deflector (7B) back tightly against the stops in the

casing. Install the rope packing (4) firmly into the groove, using a suitable tool.

6. Install the next impeller (8B) on the shaft up against the deflector (7B). Mark the shaft approximately 1/8" out and withdraw the impeller to this point. Tighten the hub securely.
7. Install the spacer (14B) into the casing. Make sure spacer and deflector (7B) are pressed back tightly and at a uniform distance from the end of the casing at four points.
8. Proceed in a like manner with remaining impellers, spacers and deflectors.
9. Reassemble the end head (6) to the casing using a new endhead gasket (12).

Balancing

Each machine is fully tested before leaving the Spencer factory to be sure vibrations, if any, are well within specifications for this particular machine. However, rough handling during shipment or improper disassembly/reassembly of a machine can upset its balance and/or result in excess vibration.

If there is any vibration due to an unbalanced condition after assembly, use the following procedure.

After running at operating speed and when at rest, mark position of end impeller hub on shaft. Loosen bolts or screws holding impeller on shaft. Rotate impeller 90° on shaft. Retighten bolts or screws. Run machine again at operating speed, and check vibration. Repeat this process until the best position is located for the impeller on the shaft so that there is no vibration in the machine.

Note: In the event of trouble, notify The Spencer Turbine Company, Windsor, Connecticut, or the nearest Spencer representative, describing in detail the nature of the difficulty before attempting to disassemble the machine.

Typical Multi-Stage Standard Overhung Type (SOH)

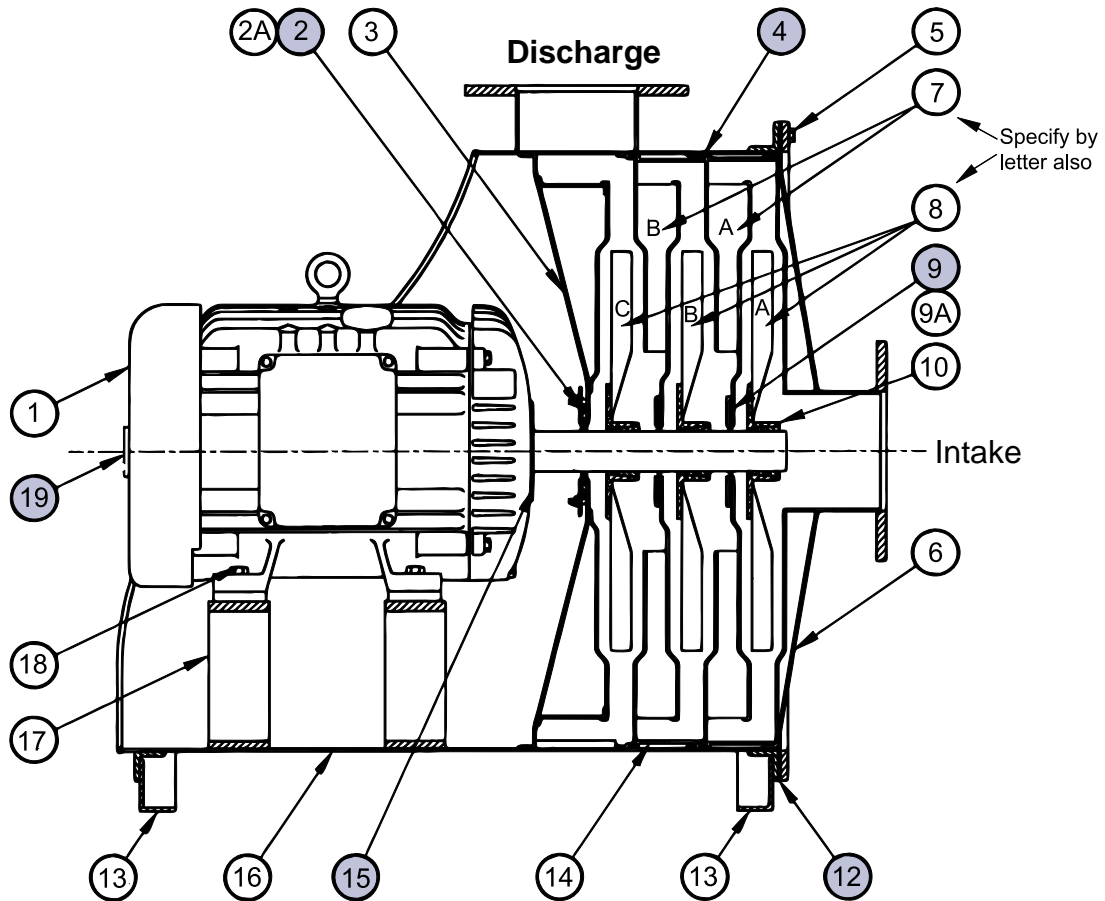

Notes:

1. Although three impellers and two deflectors are shown in this typical drawing, the number, in each machine, will vary dependent on the specific machine's design criteria. To determine the number of impellers and deflectors in a specific machine, consult the factory. Be sure to include machine serial number and appropriate impeller/deflector letter designation.

2. When ordering replacement parts, refer to Section III.



Screened items are recommended spare parts

- 1 - Motor and Shaft Assembly
- 2 - Division Head Packing
- 2A - Division Head Packing Plate
- 3 - Division Head (Not available as separate item)
- *4 - Rope Packing for Deflector
- 5 - End Head Bolts
- 6 - End Head
- 7 - Deflector (A,B, Etc.)
- 8 - Impellers (A,B, Etc.)
- 9 - Inter-Stage Deflector Packing
- 9A - Center Deflector Plates (normally not furnished on 30" or smaller machines)

- 10 - Split Clamped Hub or Tapered Bushing Clamp (Part of Impeller assembly)
- 12 - End Head Gasket
- 13 - Feet
- 14 - Spacers
- 15 - Drive End Motor Bearing
- 16 - Casing
- 17 - Motor Base
- 18 - Motor Hold-Down Bolts
- 19 - Opposite Drive Motor Bearing

* Felt on Multi-stage Adjustable Discharge Type

VI. Four-Bearing Overhung Machine

Instructions for Disassembly and Reassembly

Warning: Be sure all electrical power is disconnected prior to performing Blower maintenance.

Caution: Parts must be reassembled in exactly the same relative position. Therefore, it is recommended that each part be tagged as it is removed from the machine to facilitate later reassembly. It is especially important that the location of each impeller, as well as its position on the shaft, be marked.

When ordering replacement impellers and deflectors, refer to notes on accompanying illustrations.

General Configuration

The four bearing unit employs the overhung impeller construction with the rotating element supported by a rigid ball bearing bracket and shaft. The equipment is driven through a flexible coupling.

Disassembly

1. Remove End Head Bolts (8) and End Head (11).
2. On other than keyed construction, mark the shaft (13) and impeller (10) hub with an arbitrary 12 o'clock reference point. Remove the first stage impeller (10A) and mark it for reference during reassembly. On keyed construction, remove snap ring. Remove impeller (10A) and its hub spacer and any shims, marking them for replacement in their proper position.
3. Check axial position of each deflector (9) at four radial points with reference to end of casing and record for reference when reassembling unit.
4. Remove spacer (15) holding rope packing (18) in place. Mark spacer for reference during reassembly.
5. Remove rope packing (18) holding deflector in place. Remove deflector (9). Mark for reference during reassembly.
6. Proceed to remove remaining stages in the same way, marking each component to insure proper reassembly. Note: Division Head (4) cannot be removed.
7. Rotate the Vacuum Producer shaft (13) so that the keyway is in the 12 o'clock position. Mark the motor shaft and coupling hub to show the corresponding 12 o'clock position. Remove snap ring on Vacuum Producer side of coupling (1) and slide coupling sleeve back.
8. Remove motor mounting bolts and slide motor (23) back. Identify and secure individual motor shim packs under each motor foot for reassembly.
9. Unbolt division head packing plate (6A) and slide packing plate and packing (6) back on the shaft.
10. Mark the Blower end and coupling ends of the bracket (7) for reference. Remove bearing bracket hold down bolts and slide bracket/shaft assembly out of the casing.
11. Using heat and a puller, remove the coupling hub from the shaft.
12. Unbolt the bearing caps and remove. These caps are NOT identical so label the coupling end and blower end caps clearly. Remove the bearings (5 & 5A) from the shaft. Remove the shaft from the bracket.

Reassembly

1. Assemble the shaft (13) in the bracket with new bearings (5 & 5A) and grease. Assemble the caps, being careful to insure the correct cap on each end.
2. Using heat, assemble the coupling hub on the shaft (13).
3. Place the division head packing plate (6A) and packing (6) on the shaft. If for any reason the packing (6) is damaged, replace it. Install the bracket/shaft assembly into the casing in its original position. Be sure that the shaft is centered in the casing. Assemble the packing (6) and packing plate (6A) to the division head.
4. Move the motor (23) back into its original position. Insure an adequate gap between the coupling hubs. Align the motor (23) to the blower shaft (13) following the instructions on page 4 of this manual.
5. Rotate the Vacuum Producer shaft to the 12 o'clock position and align the corresponding mark on the motor coupling hub. Recouple the motor (23) to the shaft (13) and run the assembly to check for vibration. If excessive vibration is present, check the shaft (13) for runout.
6. On keyed construction, the impellers (10), spacers and shims are reassembled in precise reverse order of their disassembly. Verify clearance at each stage. On other than keyed construction, place the first impeller (10C) on the shaft up against the division head (4). Mark the shaft (13) approximately 1/8" behind the impeller and withdraw the impeller to this point. This will insure a clearance of 1/8" behind the impeller. Tighten the hub securely.
7. Inspect the interstage packing (14A), if applicable, on deflector (9B) and replace if damaged.
8. Place deflector (9B) back tightly against the stops in the casing. Install the rope packing (18) firmly into the groove, using a suitable tool.
9. Install the next impeller (10B) on the shaft up against the deflector (9B). Mark the shaft approximately 1/8" out and withdraw the impeller to this point. Tighten the hub securely.
10. Install the spacer (15) into the casing. Make sure spacer and deflector (9B) are pressed back tightly and at a uniform distance from the end of the casing at four points.
11. Proceed in a like manner with remaining impellers, spacers and deflectors.
12. Reassemble the end head (11) to the casing using a new end head gasket (16).

Balancing

Each machine is fully tested before leaving the Spencer factory to be sure vibrations, if any, are well within specifications for that particular machine. However, rough handling during shipment or improper disassembly/reassembly of a machine can upset its balance and/or result in excess vibration.

If there is any excessive vibration due to an unbalanced condition after assembly, use the following procedure:

1. Check coupling for misalignment. If realignment does not correct the vibration, rotate coupling hubs or machine shaft and motor shaft 90° in continuous increments.
2. If vibration persists, shut the Blower down. Mark the position of end impeller hub on the shaft. Loosen bolts or screws securing the impeller. Rotate impeller 90° on shaft. Retighten impeller. Run machine again at operating speed, and check for vibration. Repeat this process until the best position is located for impeller on shaft so that there is no vibration in the machine.

Note: In case of trouble notify The Spencer Turbine Company, Windsor, Connecticut, or the nearest Spencer representative, describing in detail the nature of the difficulty before attempting to disassemble the machine.

Typical Four-Bearing Overhung Type (4BOH)

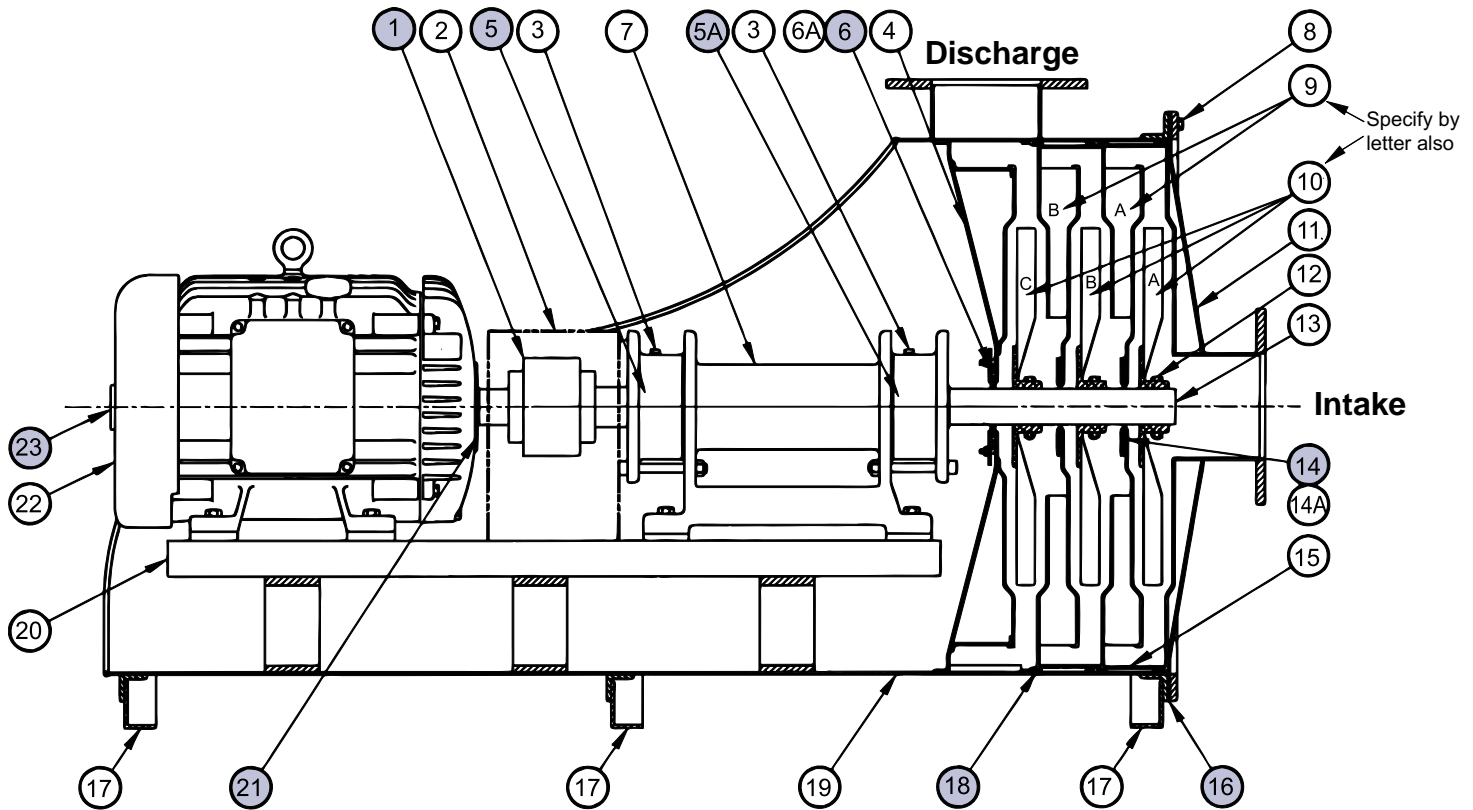

Notes:

1. Although three impellers and two deflectors are shown in this typical drawing, the number in each machine will vary dependent on the specific machine's design. To determine the number of impellers and deflectors in a specific machine, consult the factory. Be sure to include machine serial number and appropriate impeller/deflector letter designation.

2. The impellers are equipped with a split clamped hub as illustrated or tapered bushing hubs. The latter is tightened on the shaft with Allen socket screws.

3. When ordering replacement parts, refer to Section III.

 Screened items are recommended spare parts

- | | | |
|---|---|---------------------------------------|
| 1 - Flexible Coupling | 10 - Impellers (A,B,C, Etc.) | 18 - Rope Packing for Deflector |
| 2 - Coupling Guard | 11 - End Head Assembly | 19 - Casing |
| 3 - Bearing Bracket Lubrication Fitting | 12 - Impeller Bolts (or Screws) | 20 - Base for Bearing and Motor |
| *4 - Division Head | 13 - Shaft | 21 - Drive End Motor Bearing |
| 5 - Coupling End Bearing | 14 - Inter-stage Deflector Packing | 22 - Motor |
| 5A - Blower End Bearing | 14A - Center Deflector Plates (Normally not furnished on 30" or smaller machines) | 23 - Opposite Drive End Motor Bearing |
| 6 - Division Head Packing | 15 - Spacers | |
| 6A - Division Head Packing Plate | 16 - End Head Gasket | |
| 7 - Bearing Bracket | 17 - Feet | |
| 8 - End Head Bolts | | |
| 9 - Deflectors (A,B,Etc.) | | |

* Not available as a separate item

VII. Four-Bearing Outboard Machine

Instructions for Disassembly and Reassembly

Warning: Be sure all electrical power is disconnected prior to performing Vacuum Producer maintenance.

Caution: Parts must be reassembled in exactly the same relative positions. Therefore, it is recommended that each part be marked as it is removed from the machine to facilitate later reassembly. It is especially important that the location of each impeller, as well as its position on the shaft, be marked.

When ordering replacement impellers and deflectors, refer to Notes on accompanying illustrations.

General Configuration

In four-bearing units of the outboard type, the impellers are mounted between two supporting bearings of the Vacuum Producer. The equipment is driven by means of a flexible coupling, and although most standard makes of couplings can be used, a gear type is normally furnished unless otherwise specified. Standard sleeve bearing or ball bearing motors with standard shaft dimensions are included, and the entire assembly is typically mounted as shown.

Caution: Most four-bearing outboard machines have a duplex (tandem) bearing assembly. These bearings are available only from Spencer as a custom-matched set of two: one bearing for thrust and one bearing for radial load. These bearings are not interchangeable with commercially available bearings carrying the same part number; they can only be used in matched sets as furnished by The Spencer Turbine Company. For best results, follow instructions enclosed with each matched set of bearings.

Disassembly & Reassembly

1. Remove packing plate nuts from packing plate (32 and 20) on each end of machine. Slide both packing plates and packing (32 and 20) on shaft away from heads. Remove all packing from packing box when applicable (38 & 39).
2. Remove snap ring and back off coupling sleeve. Check gap between coupling hubs. See coupling manufacturers instructions for other than Sier Bath.
3. Measure distance "B" from outboard bearing bracket (19) to outboard bearing cap (17). Remove bolts in thrust assembly housing cap.
4. Remove lock nut (15) and washer from end of shaft, and loosen bolt (21) binding housing in bracket.
5. Remove bracket bolts (19A). Using puller, remove complete thrust assembly and bearings.
6. Remove bolts on end head, holding flat ring and end head to casing. (Use a chain hoist if available to hold head while removing bolts). After removal of end head, keep shaft supported while removing internal parts.
7. Remove intake spiral (13) after marking position to insure correct reassembly. See note (A).
8. Remove rope packing (10) and half deflector (26).
9. On other than keyed construction measure distance from impeller hub to any step or shoulder on shaft, and mark for reassembly. On stacked and keyed construction, remove nuts and washers (24A) and shaft sleeves (24B). Remove impeller (29) and its hub spacer, number or mark them for replacement in their proper position. See note (B) following paragraphs.

10. Check axial position of each deflector at 4 radial points with reference to end of casing and record.
11. Remove spacer (27) holding rope packing in place. Number or mark for replacement.
12. Remove rope packing holding deflector in place. Then pull or work deflector (11) out of casing. Number or mark for replacement.
13. Proceed to remove the remaining stages in the same way, numbering or marking all impellers, spacers, deflectors, etc., to insure proper replacement.
14. Check deflector stops for damage.
15. Reassemble in reverse order, replacing end head gasket (22) and any worn packing (32, 10, 25, 20).

To Change the Inboard Bearing (Motor End of the Machine)

1. Remove snap ring and back off coupling sleeve.
2. Check gap on coupling hubs.
3. Loosen and remove motor bolts, and slide motor back.
4. Remove coupling hub from machine shaft.
5. Remove packing plate nuts from packing plate (32 and 20) on each end of machine. Slide both the packing plates and packing (32 and 20) on the shaft away from the heads. Remove all packing from packing box where applicable.
6. Remove bolts on both caps (8 and 8A) on three-arm bearing bracket (33).
7. Slide front cap off shaft, and push back cap away from bracket.
8. Remove bolts holding inboard bracket in position while supporting end of shaft.
9. Slide inboard bracket off bearing.
10. Remove locknut, washers, and bearing.
11. Replace bearing and parts in their proper order.

Realign coupling and check the hub before and after bolting motor in place (Refer to page 4).

Notes:

- (A) Upon reassembly, with all internal parts installed, the intake spiral edge should project slightly beyond end of casing so that end head will hold all stationary parts in position.
- (B) On stacked and keyed impeller construction, the first nut installed is tightened with a spanner wrench, then loosened one full turn to allow for impeller hub expansion. The second nut is brought up to the first nut with the lockwasher in between. Lock nut in position with washer tabs.

Balancing

Each machine is fully tested before leaving the Spencer factory to be sure vibration, if any, is within specifications for the particular machine. However, rough handling during shipment or improper disassembly/reassembly of a machine can upset its balance and result in excess vibrations.

When a machine is being disassembled for repairs, mark the parts as they are removed. If this is done, no trouble should be expected from vibration when they are re-assembled in the same order.

However, if the impellers are being replaced or there is any vibration due to an unbalanced condition after assembly, use the following procedure:

If there is any vibration or unbalance, the coupling should be checked first for misalignment. If realignment does not correct imbalance, rotate coupling hubs or machine shaft and motor shaft in 90° increments until minimal vibration is obtained.

Typical Four-Bearing Outboard Type (4BOB)

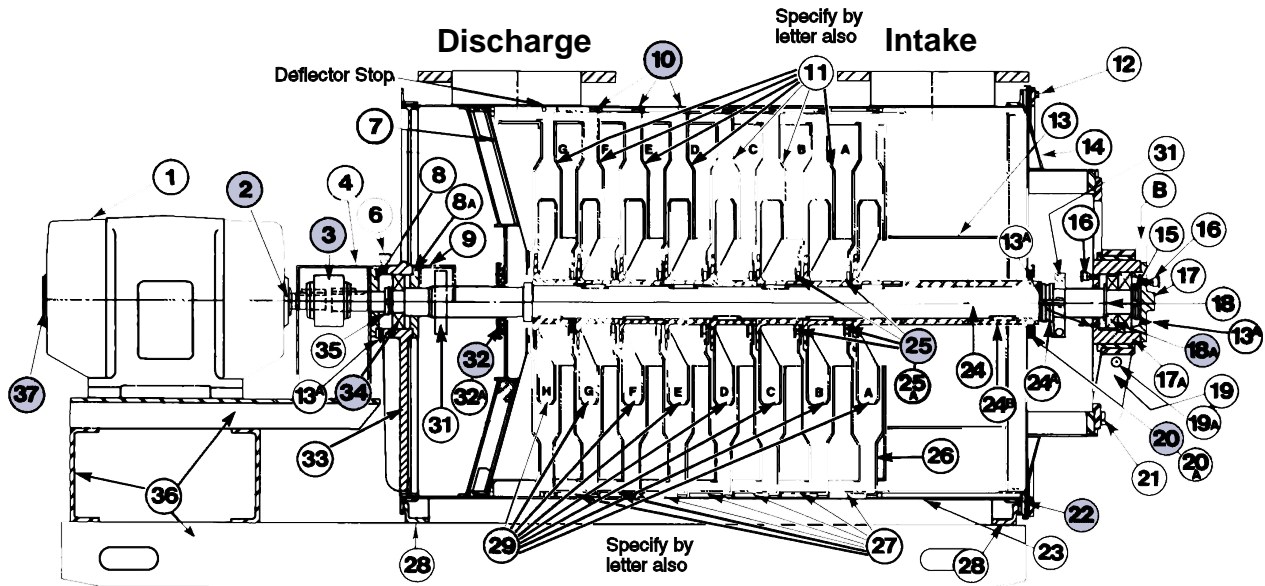

Notes:

1. Although eight impellers and seven deflectors are shown in this typical drawing, the number in each machine will vary dependent on the specific machine's design criteria. To determine the number of impellers and deflectors in a specific machine, consult the factory. Be sure to include machine serial number and appropriate impeller/deflector letter designation.
2. The impellers are equipped with keyed hubs as illustrated or split clamped hubs shown below.
3. When ordering replacement parts, refer to Section XIV.

 Screened items are recommended spare parts

- | | | |
|---|--|---|
| 1 - Motor | 15 - Outboard Bearing Nut and Washer | 25 - Inter-Stage Deflector Packing |
| 2 - Drive End Motor Bearing | 16 - Outboard Bearing Lubrication Fitting | 25A - Center Deflector Plates |
| 3 - Flexible Coupling | 17 - Outboard Bearing Cap | 26 - Half Deflector |
| 4 - Coupling Guard | 17A - Outboard Bearing Housing | 27 - Spacers |
| 6 - Inboard Bearing Lubrication Fitting | 18 - Thrust Washer (where applicable) | 28 - Feet |
| *7 - Division Head | 18A - Outboard Bearing(s) | 29 - Impellers (A,B, C, Etc.) |
| 8 - Inboard Bearing Cap Front | 19 - Outboard Bearing Bracket | 31 - Heat Fan |
| 8A - Inboard Bearing Cap Rear | 19A - Housing Locking Bolt and Nut | 32 - Division Head Packing |
| 9 - Heat Fan Guard | 20 - End Head Packing (where applicable) | 32A - Division Head Packing Plate |
| 10 - Rope Packing for Deflectors | 20A - End Head Packing Plate | 33 - Inboard Bearing Bracket |
| 11 - Deflectors (A,B,C, Etc.) | 21 - Bracket Bolts | 34 - Inboard Bearing |
| 12 - End Head Bolts | 22 - End Head Gasket | 35 - Inboard Shaft Locking Nut and Washer |
| 13 - Intake Spiral | 23 - Casing | 36 - Common Base |
| 13A - Grease Drain | 24 - Shaft and Keys | 37 - Opposite Drive End Motor Bearing |
| 14 - End Head Assembly | 24A - Impeller Assembly Lock Nuts (2) and Washer (1) | 38,39 - Metallic Packing |
| | 24B - Shaft Sleeves (Two; one keyed) | |

* Not available as a separate item

Alternate internal construction of a four bearing outboard Blower with split clamped hubs

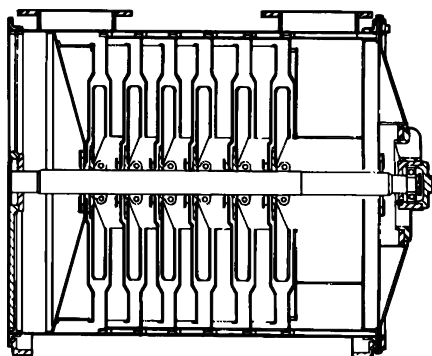

Packing box used on Gas Boosters. See Form DD

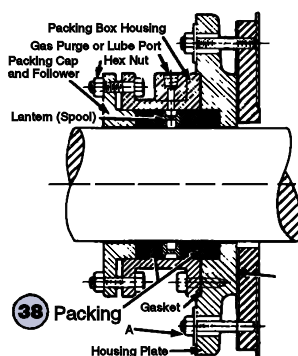

Packing box used where pressure exceeds 7.5 psi and for other special applications.

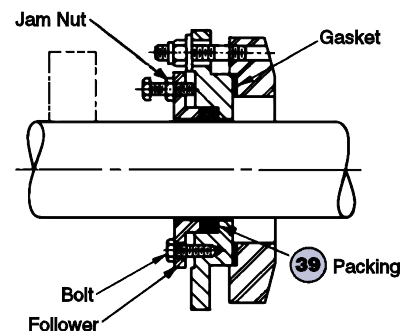

VIII. Centrifugal Separator

To assure efficient operation the separator must be sealed properly to prevent leakage. The access doors, dirt can, discharge valve, intake and outlet should be checked as the most common places for leakage.

The separator should not be allowed to become so full that the accumulated litter interferes with its efficiency. The separator should be emptied at regular intervals.

Note: After each cleaning period the wire screen over the baffle inside the separator should be brushed to remove accumulated litter. The screen can be reached through the hand hole at the front of the separator. Failure to clean screen will diminish suction.

Caution: Be sure to shut down the system before attempting to clean.

The dirt can type separator is cleaned by removing and dumping the dirt can. Be sure the dirt can is properly seated when it is replaced.

The hopper bottom separator is cleaned by opening the discharge valve in the cone of the separator and allowing the material to drop into a container or discharge line.

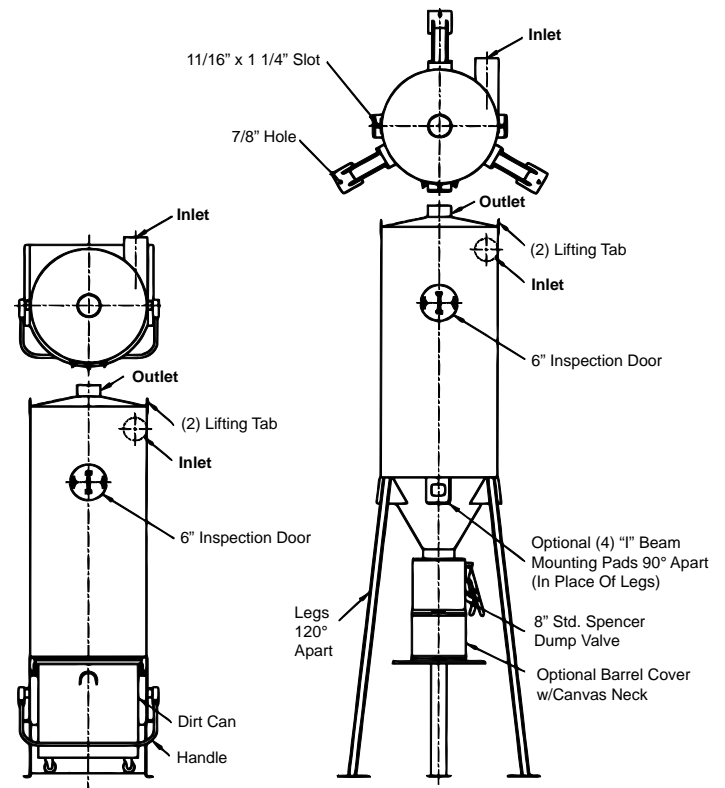

Centrifugal Separator with Removable Dirt Can

Centrifugal Separator with Hopper Bottom

IX. Tubular Bag Separator

To assure efficient operation the separator must be sealed properly to prevent leakage. The access doors, dirt can, discharge valve, intake and outlet should be checked as the most common places for leakage.

After each cleaning period the bags should be thoroughly shaken. Bags should also be checked for wear periodically and replaced if needed. See bag installation instructions.

The dirt can type separator is cleaned by removing and dumping the dirt can. Be sure the dirt can is properly seated when it is replaced.

The hopper bottom separator is cleaned by opening the discharge valve in the cone of the separator and allowing the material to drop into a container or discharge line.

Caution: Be sure to shut down the system before shaking bags or attempting to clean.

Motorized Bag Shaker

Caution:

The motorized bag shaker gearbox has been shipped with gearbox lubricant. The gearbox must be serviced prior to start-up in accordance with the manufacturer's instructions regarding type of lubricant used and servicing interval.

Motorized bag shaker linkage rod end bearings have been lubricated at the factory and should be re-lubricated every three months.

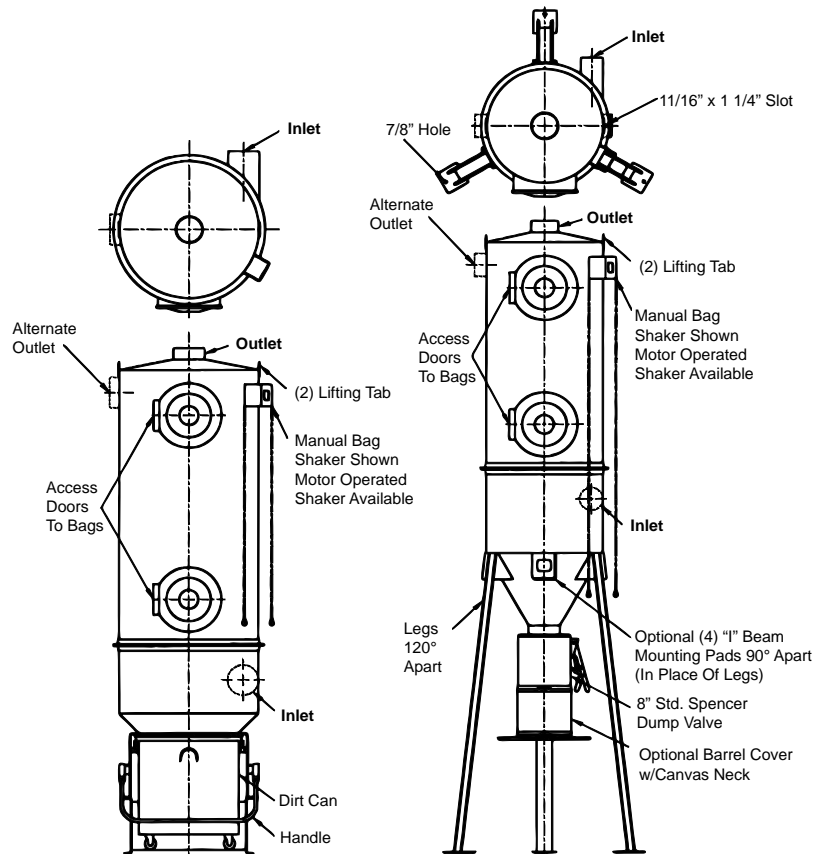

Tubular Bag Separator with Removable Dirt Can

Tubular Bag Separator with Hopper Bottom

XI. Wet Separator

The Wet Separator will be supplied for wet material pickup and water flushing. This separator will have a ball float shutoff, a float switch flange, and a 1 1/2" FPT pump connection. The standard float switch flange is for pump operation, and when an overflow control is required a special float switch flange will have to be added above the standard one. When a pumping arrangement is not required the 1 1/2" FPT pump connection will be plugged and the float switch flange will be capped.

To insure proper operation of the separator check all connections and inspection doors to be sure they are properly sealed and do not leak air into the system.

The separator should not be allowed to become so full that the accumulated material interferes with its efficiency.

After each cleaning period the separator should be cleaned according to the following procedure:

1. Shut down the Vacuum Producer.
2. Pour required disinfectants into funnel.
3. Open lower water tap, so slurry of dirt in solution will form.
4. Open upper water tap to aid in filling separator.
5. Close upper water tap after approximately:
 - 1 minute for 24" separator
 - 2 minutes for 30" separator
 - 3 minutes for 36" separator
6. With lower water tap open to continue whirlpool action of solution, open discharge valve to sewer, to flush out separator.
7. Proceed with flushing action until discharge water becomes clean.
8. Close lower water tap and let separator drain-out.
9. Close discharge valve to sewer.
10. System can now be used for vacuuming.

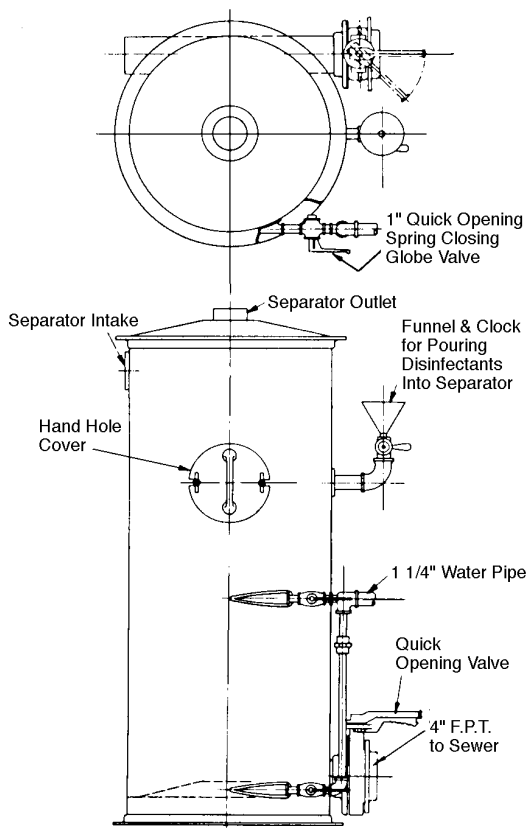

XII. Portable Wet Separator

The separator is used for picking up wet solutions and is not intended for general cleaning.

It is connected to the system by the use of a short length of hose. The male end of the hose is plugged into an inlet valve of the main system. The female end of the hose is attached to the 1 1/2" hose coupling at the top of the separator.

The separator should be drained and flushed after each use. It is flushed by removing the cover assembly and pouring in clean water while the faucet on the separator is open and draining.

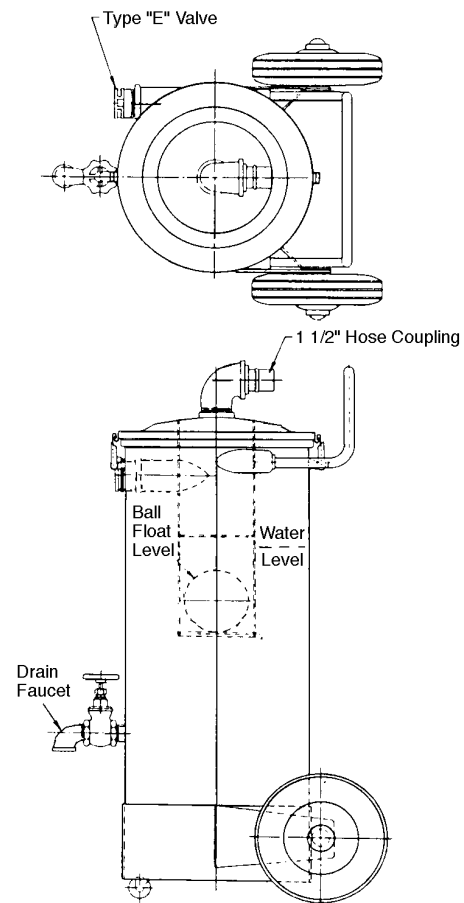

XIII. Trouble Shooting Guide - Separators

Trouble	Probable Cause	Corrective Action
Centrifugal Separators		
Vacuum Producer Motor Overload	– Leaks.	Check access doors for tightness. Check dirt can or discharge valve sealing. Check for holes worn in separator (when handling abrasive materials).
Low Vacuum in System	– Leaks. – Screen Clogged.	See above. Clean screen (access through clean-out door in side of Separator).
Majority of Material Not Being Collected	– Leaks.	See above. A small leak will greatly affect separation efficiency.

Tubular Bag Separators

Vacuum Producer Motor Overload	– Leaks.	See above.
Low Vacuum in System	– Leaks. – System Overload – Bags Clogged	See above. See Vacuum Producer Trouble Shooting Guide. Shake bags at more frequent intervals (only shake bags when system is not running). Air leaks blowing debris into filter eliminate leaks.
Dirt Passing Through Separator and Clogging Vacuum Producer or Being Exhausted	– Loose bag. – Holes in bags. – Incorrect filter material.	Check bags and re-install per instructions. Carefully examine bags for holes and replace defective bags. Contact factory.

XIV. Trouble Shooting Guide

Trouble	Probable Cause	Corrective Action
Insufficient air through system	<p>Low vacuum as determined by measurement with a manometer or vacuum gauge:</p> <ul style="list-style-type: none"> – Incorrect rotation. – Customer has reassembled machine incorrectly. – Machine sized for requirements given, but air lines too small causing excessive frictional loss. – Valves in line, causing excessive losses. – Inlet or outlet partially blocked, i.e., blast gate shaft slipped in handle and shutter does not open fully. – High inlet temperature, i.e., higher than designed inlet temperature. – Lower inlet pressure, i.e., lower than designed inlet pressure. – Machine not running at designed speed. – Machine air passages clogged with material. – Impellers worn out due to explosion, abrasion, or vibration. – Inlet spiral has rotated partially blocking inlet (4-bearing outboard machines only). <p>Machine design capacity too small for the system:</p> <ul style="list-style-type: none"> – System requirements incorrectly calculated by customer. – Too many leaks and/or openings. <p>Measuring gas or air flow incorrectly:</p> <ul style="list-style-type: none"> – Flowmeters incorrectly calibrated. – No means of measurement available so customer is guessing at airflow. 	<p>Change motor leads to correct rotation.</p> <p>Refer to instructions in this book and to assembly print; disassemble machine and reassemble properly.</p> <p>Increase line sizes or install machine providing higher vacuum.</p> <p>Install larger valves or install machine providing higher vacuum.</p> <p>Check blast gate; remove and repair if necessary.</p> <p>Direct inlet line to cooler area; replace machine with one designed for correct temperature.</p> <p>Remove inlet restrictions or install machine providing higher vacuum.</p> <p>Refer to motor manufacturer's instructions; check motor speed; check voltage connections.</p> <p>Disassemble, clean and inspect all parts.</p> <p>Replace Impellers.</p> <p>Rotate spiral to correct position and pin or clamp in position.</p> <p>Install larger volume or higher vacuum machine to handle correct system requirements.</p> <p>Locate and repair all leaks.</p> <p>Calibrate flowmeters; be certain proper orifice is used for meter (check with flowmeter manufacturer).</p> <p>Obtain and install flowmeter.</p>
	<p>Machine noisy</p> <p>External machine malfunction – bearing whining or growling:</p> <ul style="list-style-type: none"> – Too much grease – bearing hot. – Too little grease – bearings dry. – Bearing(s) failure. – Bearing retainers worn. – Bearings turning on shaft – retaining nut loose. – Bearing turning in housing – housing worn. – Bearings replaced incorrectly – particularly in tandem assembly, i.e., angled, cramped or put in backwards. – Bearing(s) overloaded – too much thrust due to higher density gas or air than designed for. <p>Internal machine malfunction:</p> <ul style="list-style-type: none"> – Impeller(s) hitting after customer reassembly and/or Impeller(s) slipping shaft due to heat or excessive inlet pressure. – Impeller(s) coming apart due to age or wear from dirty air. – Deflector coming apart due to age or wear from dirty air. – Machine operating in surge or unbalanced flow range. – Keyed hubs rattle on start up. – Machine out of balance running rough. – Deflector packings rubbing on shaft or Impeller hub (will seat themselves if new). – Motor not aligned in casing (Standard Overhung) causing Impeller to hit. – Four-bearing machines – coupling misaligned and/or dry of grease. – Foreign material in machine. 	<p>Remove excess grease. Check bearing temperature (refer to lubrication instructions in this manual).</p> <p>Grease according to instructions.</p> <p>Replace bearing(s).</p> <p>Replace bearing(s).</p> <p>Tighten nut, check for damage.</p> <p>Replace housing and bearing.</p> <p>Install bearings correctly according to instructions: check bearing, shaft and housing dimensions.</p> <p>Replace bearing(s). Reduce thrust by lowering gas or air density, installing smaller Impellers, or installing machine designed to proper conditions.</p> <p>Reassemble according to instructions, tighten Impellers. Bleed air at low flow to reduce heat. Change inlet conditions if necessary.</p> <p>Replace Impeller(s).</p> <p>Repair or replace deflector.</p> <p>Increase air flow to stop surge condition.</p> <p>Normal. These will be loose when machine is cold – they will tighten as machine reaches operating temperature.</p> <p>Rebalance and/or clean machine (See next problem – "Machine Vibrating").</p> <p>Ignore if audible only when machine turned by hand.</p> <p>If otherwise audible, replace packings.</p> <p>Reassemble and carefully align shaft and motor properly.</p> <p>Check alignment; check coupling for wear and replace if necessary. Relubricate according to instructions.</p> <p>Disassemble machine, inspect and clean. Reassemble and, if necessary, install filter to prevent further clogging.</p> <p>Refer to Separator sections.</p>

Trouble	Probable Cause	Corrective Action
	<p>Motor malfunctions:</p> <ul style="list-style-type: none"> - Electric hum or whine – some usually normal. - Wrong voltage – low voltage motor not up to speed. High voltage will burn out motor and also cause noticeably more noise. - Bearing (see above) - Motor rebuilt improperly – thrust taken on wrong end in standard overhung machine. - Loose part in motor. - Low frequency. 	<p>Check motor manufacturer's instructions. Check voltage supply and connections. Check for proper voltage at motor and correct.</p> <p>Rebuild motor properly and correct end play.</p> <p>Tighten, repair or replace (check with motor manufacturer). Separate power supply; correct frequency.</p>
Machine vibrating	<p>Imbalance:</p> <ul style="list-style-type: none"> - Material build-up on Impeller(s). - Shaft bent – possibly in shipment – (.001 maximum shaft run per 10" of length for standard and 4-bearing overhung machines. - Bearing(s) failure. - Faulty replacement motor installed and /or machine reassembled incorrectly. - Impeller(s) failure. <p>Mechanical:</p> <ul style="list-style-type: none"> - Motor not aligned in casing (standard overhung & 4-bearing overhung), Impeller rubbing. - Coupling misaligned (4-bearing machines). - Inlet and/or outlet piping connected to machine without flexible connector causing torque or strain on casing. - Machine bolted down causing change in alignment. - Bearing(s) cramped due to improper fit. - Tubing not properly supported. - Improper voltage on motor causing assembly to operate at different speed. - Packing box(es) too tight, too loose, wrong packing, packing dried out and/or worn out, out of alignment. Mechanical seals misaligned, broken or worn out. - Solids or liquids in, or passing through machine. - Machine operating in surge or unbalanced flow range. - Stacked Impeller hub nuts too tight. - Belts on belt drive machine loose – slapping. - Harmonic pulsation from gas engine driver. - Machine not mounted on solid foundation, i.e., on unstable catwalk, etc. 	<p>Clean Impeller(s); check separator filters. Replace shaft.</p> <p>Replace bearing(s). Disassemble machine, balance motor, reassemble according to instruction in this book and assembly print. Replace Impeller(s).</p> <p>Align motor, realign shaft.</p> <p>Align coupling. Install flexible connection at inlet and outlet.</p> <p>Remove bolts; use dowel pins or set in guide channels. Check bearings, shaft and housing, correct bearing fit. Properly anchor tubing beyond flexible connector. Check voltage and wiring connections; correct voltage.</p> <p>Adjust, relubricate or replace packing; align box(es). Realign or replace seals or parts.</p> <p>Disassemble, inspect and clean machine, install filter to prevent further contamination. Increase air flow to stop surge condition. Loosen hub nuts 1/2 turn. Tighten belts to proper tension. Do not operate at this speed! Change motor speed enough to remove harmonic pulsation. Re-inforce foundation.</p>
Motor Hot (Can be checked with surface thermometer. Refer to factory for decision as to whether or not it is too hot.)	<p>Incorrect motor selection:</p> <ul style="list-style-type: none"> - Ambient temperature too high for insulation class. - Incorrect voltage. - Incorrect cycle. - Electrical short-circuit insulation failure. - Motor overloaded – blower too small for system. <p>Unbalanced voltage supply: Applies to gas boosters only.</p>	<p>Cool motor or replace with motor having proper insulation. Change to correct voltage. Change to correct cycle. Repair or replace motor. Install larger motor and/or blower.</p> <p>Check with power company for correction.</p>

Refer to page 5 for Replacement Parts information.



Products & Services

Industrially rated products offering effective solutions for air and gas moving problems:

- Modular central vacuum systems
- Mobile or stationary integrated vacuum units
- Dust collectors and separators
- Multi-stage centrifugal blowers
- Single stage centrifugal blowers
- Regenerative blowers
- Gas boosters
- Custom-engineered products with special materials for extreme temperatures and pressure

Complementary accessories with single source convenience and compatibility:

- Electrical control panels including UL and CUL Listed, standard and custom designs
- Comprehensive selection of tubing, fittings, vacuum hoses, valves and tools
- Valves, gauges, couplings, shrink sleeves, vibration isolators and other system components

Comprehensive engineering and other customer support services:

- The industry's largest complement of technical specialists in air and gas moving technology
- Worldwide parts and service organization
- Application research and testing facility
- Product selection process aided by internal computer program

Worldwide organization of sales representatives and distributors offering:

- Product selection, installation and operation assistance
- Comprehensive system design services
- Follow-up services and troubleshooting

***For the name and telephone number of your local
Spencer representative, call 800-232-4321
or email marketing@spencer-air.com.***