



combination steamer-ovens.  
steam jacketed kettles.  
braising pans.  
smartsteam 100 steamers.  
intek steamers.  
hypersteam steamers.



# core products



mobile system serving lines.  
ranchef chef tables.  
custom chef tables.  
chef/equipment stands.  
high volume prep tables.  
raised rail prep tables.



utility distribution systems.  
conveyor systems.  
ecoarch ventilation systems.

Since its inception in 1907, Groen has enjoyed a strong reputation for innovation and quality of its steam foodservice equipment. We were the first to introduce steam jacketed kettles, boilerless steamers, braising pans and combination steamer-ovens to the US.

### **ComboEase™ Combination Oven-Steamers.**

You may already know about the benefits of combination ovens - the savings in labor and space, the versatility of a single unit to replace a steamer and convection oven, faster cook times, the reduced food shrinkage and higher yields, and food that's more flavorful and nutritious.

But what you may not know is one combi truly gets the job done more easily - the ComboEase from Groen. Easy to learn, operate and maintain, easy on the budget and the environment — in today's dynamic and ever-challenging kitchen, no full-size combi breathes simplicity like the ComboEase.



“the stainless steel-jacketed kettle from groen revolutionized the industry”



### **Steam Jacketed Kettles.**

No hot-spots. No constant stirring. And no large stock pots to wrestle on and off a range top. A Groen kettle cooks faster, is much easier to clean, and saves you time and money.

The 2/3 jacket coverage of a Groen kettle provides the kitchen with a one-pot cooking vessel for preparing soups, sauces, stews and custards. An appliance that comes to temperature quickly, heats evenly and gently, and distributes the heat over the largest surface area so that food does not burn or scorch.

### **Eclipse™ Ergonomic Tilting Braising Pans.**

The Groen Eclipse Braising Pan is a multitasking, hard-working, high performance braising pan, combines the functions of a skillet and a kettle, and is so versatile it can retherm, grill, braise, hold, steam, boil, or cook just about anything you can dish up.

When not cooking food, the braising pan can also be used as a water bath holding point for sauces, soups and other prepared items.



“ offers the convenience of boilerless steamers with twice as much cooking power ”

## SmartSteam100™ Boilerless Steamers.

The SmartSteam100 from Groen is the “smart” solution for high speed, production steaming. Featuring a boilerless steam generator inside the steamer compartment, it has the power to cook fast and to recover quickly every time the door is opened. Featuring automatic fill and drain, all operations are controlled through a microprocessor and a simple touch-button control. No boiler maintenance and easy access to all areas of the steamer elevate SmartSteam100 to the top of its class.

The Rapid food production retains the flavor, freshness, nutrients and texture that makes food appealing.

## Intek Connectionless Steamers.

The Intek Connectionless Steamer has the best possible combination of cooking speed (productivity), efficiency, and reliability of any steamer on the market today.

Some conventional steamers cook faster than an Intek, but they use 1,000 times as much water and 3 times as much energy to cook the food. Some connectionless steamers are as efficient as an Intek, but they cook slower or are not as reliable.

Intek is ENERGY STAR® listed and qualifies for purchase rebates offered by leading utilities in states throughout the US.



## HyPerSteam™ Pressureless Convection Steamers.

With twin, independent steam generators on most double-stacked and dual-cavity models, the HyPerSteam from Groen is dependable and reliable.

The powerful internal blower increases steam velocity for faster cook times. A free venting drain eliminates flavor transfer. Featuring a two-probe warning system for delimiting, auto-clean delimiting from a touch pad, a large drain port to better resist lime and scale build-up, and instant steam from the “ready” mode.

“ a standard that far surpasses pressure steamers ”





# Randell, with its line of foodservice refrigeration, serving and custom fabrication, was established in 1975. As a leader in refrigeration technology, we keep your products fresh and safe for the toughest of food critics.

## RanServe™ Mobile Serving Lines.

Randell's RanServe mobile serving equipment allows the ultimate in design flexibility by attaching standard module units to form a service line to fit your menu and space constraints. Configurations are endless. Units can be built with stainless steel, laminate or fiberglass exteriors. With hot wells, frost tops, cold pans, freezers, refrigerated back-up storage, tray and silverware stands, open storage and a variety of cashier stand options, RanServe makes sense in every school system.



“form and functionality marry for the ultimate budget conscious solution — start with the shell and fill in the spaces”

## RanChef™ Chef Tables.

Just the right blend of Randell's premium performance standard items and our custom fabricated shelving units and overshelves to meet functional needs operationally, while meeting budget constraints.

“Wing-walls” are the key. These shells support the overshelves and allow standard catalog units to slide in and out for cleaning, servicing or rearranging. Savings on a typical center-island chef's table can be anywhere from 10-30%!

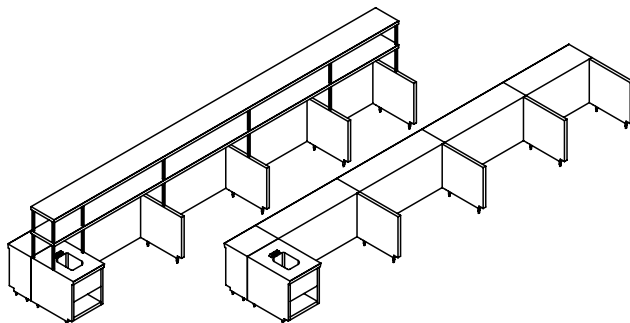

RanChef units are perfect for any operation where budget constraint trade-offs require something less than heavy-duty custom fabricated counters.

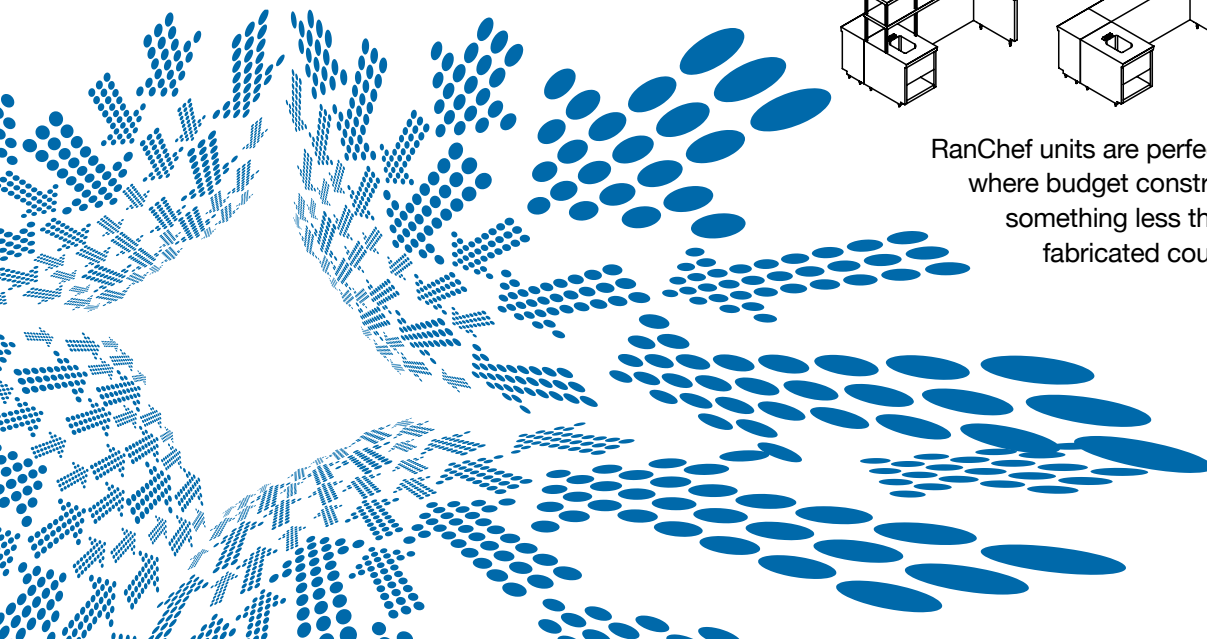

“randell systems run 25° cooler than traditional designs”

Prepare, Hold & Serve. 

### Chef/Equipment Stands.

Randell stands come with our patented heavy duty drawer cartridge system with a 3-year warranty on the entire drawer system. Drawers have fully welded unitized cartridge assemblies, heavy duty full extension tracks, quick release, and are self-closing. The unit is 100% front breathing, and comes with exclusive press-fit gaskets and a reinforced top to handle the heaviest loads.



### Custom Chef Tables.

Like the RanChef units, begin with Randell's modular, pre-designed units. Decide what you need and how you want them lined up. Customize the chef and waitress sides with endless options. Then sit back and let Randell do the work.

Custom chef tables can be loaded with options such as soup wells, pre-wired overshelves, sinks, single point connections, warming drawers, heat lamps, storage racks... The possibilities are endless.

And don't forget about the standard features such as a more efficient refrigeration system, patented drawer systems and exclusive press-fit gaskets.



### 9000K High Volume Prep Tables.

9000K prep tables are efficient and versatile performers, without the addition of a raised rail. Ideal for sandwich and sub shops, the optional drawers provide bulk salad storage and are great for salad prep.

The effective cooling above the pan line — without risk of freezing — is achieved by moving cold air over the top from front to back. With the exclusive ducted air-flow, less velocity is needed to provide the cold blanket of air above the food which will create less drying out of delicate products.

Air is not exhausted out the back so the units require less space while cooling more efficiently.

Many more features on both the prep table units include press-fit gaskets, high impact ABS door jams, lift-off or hinged louvers and full depth interiors.

### 8000N Raised Rail Prep Tables.

Our exclusive mechanically-cooled raised rail offers easy access to food pans and meets strict food safety temperature pan requirements.

The exclusive cold wall conductive cooling design transfers cold efficiently through recessed food pans — instead of trying to force cold from the bottom only.

For food safety precautions, the raised rail is sealed to the base to prevent spills from contaminating food stored in the refrigerator below. And only Randell's raised rail has a standard oversized rail drain to easily drain water and debris from inside the rail.

An independent rail thermostat allows adjustment of the base and rail temperatures separately.

Side-mounted compressors are cooled without exhausting hot air through the back or side of the unit. This exclusive design enables the compressor to run 25° cooler, and you can build the unit in with zero clearance or curb-mount it.

“at night, shut off the rail to save 50% or more on utility costs”



**Avtec, a manufacturer of ventilation and air handling systems, was founded in 1971. Never content to follow others, Avtec has always sought out better, more efficient ways to enhance working environments.**

### **Utility Distribution Systems.**

A Utility Distribution System (UDS) is a stainless steel raceway installed underneath the kitchen hood and is designed to house the utilities for all the cooking equipment. UDSs are pre-engineered, UL listed, and offer a single point connection for all utilities including: electricity, gas, water, and steam. The utilities for the equipment under the hood simply hook-up to the outlets provided in a stainless steel raceway — reducing installation costs. Just unplug the unit and remove the quick snap disconnects and the cooking equipment rolls out of the way for cleaning.

The UDS eliminates the need for running the utilities for the cooking appliances in a contractor built wall and also the expensive charges incurred when those appliances or utilities change.

**“raceways are customized to meet specific needs so that the entire system, or just one unit, can be relocated exactly where needed”**



### **Conveyor Systems.**

Let's face it, no two commercial foodservice kitchens are alike. Avtec designs and engineers conveyor systems with the largest available design variations to meet the exact needs of foodservice facilities.

With Avtec's outstanding reputation for innovative technology and reliability, we have the experience to deliver a customized solution that will fit any need or budget.

Avtec conveyors are constructed of a uni-body 100% stainless steel construction and are assembled and tested prior to shipping to the field. Due to the uni-body assembly, field adjustments to the frame are a thing of the past.

Choose from Bus-Trac conveyors, ideal for cafeteria soiled tray return, Slat Belt conveyors, ideal for cafeteria soiled tray return and dishroom accumulation, or Cordveyor conveyor systems, ideal for cafeteria soiled tray return and tray make-up.





“ commercial kitchen hood system that can operate at volumes up to 50% less than a traditional hood ”

## EcoArch™ Energy Efficient Ventilation Systems.

Since its introduction in 2007, the Avtec EcoArch has taken the Commercial Kitchen Ventilation Industry by storm and with good reason. The EcoArch hood is the most energy efficient, operations friendly, exhaust only hood in the market today.

The EcoArch hood was a winner of the 2008 Kitchen Innovations Award given at NRA and was the first ventilation product to have ever won the award. The energy efficient design draws on the combination of our innovative interior arch top and front mounted high velocity exhaust slot.

The result is a commercial kitchen hood system that can operate at volumes up to 50% less than a traditional hood translating to substantial energy savings.

The arched interior results in the quietest operating system on the market and saves time in cleaning while lending safety to kitchen personnel. The front mounted exhaust filters mean that personnel no longer have to stand on top of cooking equipment to remove them for cleaning.



# Food Safety & Energy Conservation.



Unified Brands vision is to be the world class provider of foodservice equipment solutions and systems that makes possible safe and nourishing foods for people around the world.

At Unified Brands, we believe that utility conservation and energy efficiency are paramount to protecting our environment and ensuring the safety of food supplies for future generations. That's why select products in the Avtec, Groen and Randell product lines bear the ENVIROSAFE Standard mark of distinction. Because they've been rigorously tested and proven to exceed standards of environmental and food safety excellence.

## FOCUSED ON FOOD SAFETY.

Products meeting the ENVIROSAFE Standard are manufactured using durable, non-toxic materials to cook and/or hold food safely, meeting exacting requirements for precise temperature control, ease-of-cleaning, and sanitation effectiveness.

## SAVE ENERGY. SAVE THE ENVIRONMENT.

Unified Brands is committed to the responsible conservation of our planet's natural resources. So you can rest assured that each and every one of our products bearing the ENVIROSAFE Standard mark of distinction has been designed to use significantly less energy, and cost less to operate, than other products in the same category – without sacrificing performance or food safety.

## THE ENVIROSAFE ADVANTAGE.

Guaranty energy efficiency. Qualify for government rebates and incentives. Ensure the safety of your food products.

For more information and a list of products bearing the ENVIROSAFE Standard mark of distinction, visit [www.unifiedbrands.net](http://www.unifiedbrands.net).

## INDUSTRY & NATIONAL RESOURCES

### **ENERGY STAR** [www.energystar.gov](http://www.energystar.gov)

Partner and product listings, savings calculators, listings for special offers, rebate opportunities, incentives, and more.

### **NSF** [www.nsf.org](http://www.nsf.org)

Certified products and listings, articles, regulatory and public health information, plus HACCP compliance, and more.

### **ENVIRONMENTAL PROTECTION AGENCY** [www.epa.gov](http://www.epa.gov)

Conservation, regulatory, and other helpful information.

### **CENTERS FOR DISEASE CONTROL** [www.cdc.gov](http://www.cdc.gov)

Food safety, nutrition, and other crucial health information.



PRINTED ON  
RECYCLED PAPER



888.994.7636  
[unifiedbrands.net](http://unifiedbrands.net)

Unified Brands is one of many individual operating companies of Dover Corporation, a multi-billion dollar, global manufacturer of industrial products. The product lines of Unified Brands—Groen, Randell, Avtec and CapKold—have leading industry positions in cooking equipment, cook-chill production systems, custom fabrication, foodservice refrigeration, ventilation and conveyor systems. Headquartered in Jackson, MS, Unified Brands operates manufacturing facilities in Weidman, MI and Jackson, MS.

Information contained in this brochure is known to be current and accurate at the time of printing. Unified Brands recommends referencing our website for updated and additional information.